



Technical information **The Citaro Ü**



Mercedes-Benz

Model variants

Citaro Ü (C628.087)

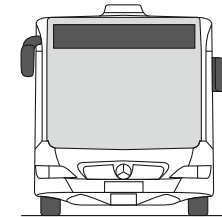
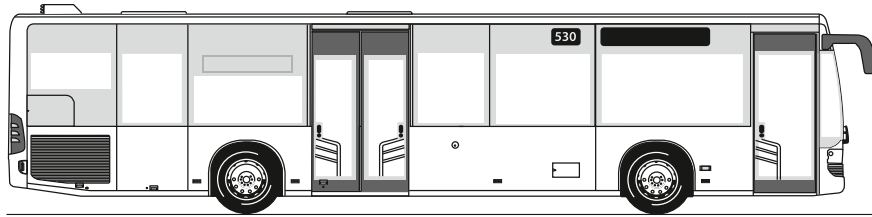

Citaro MÜ (C628.487)

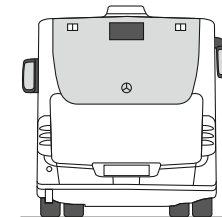
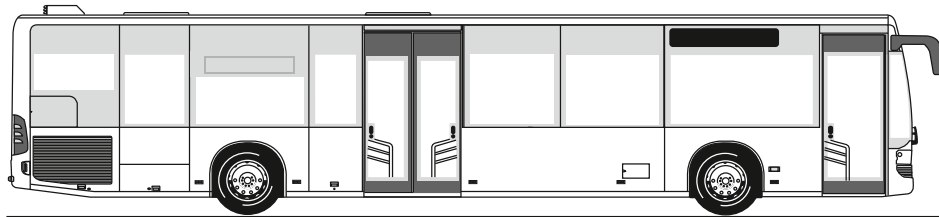

Citaro LÜ (C628.187)

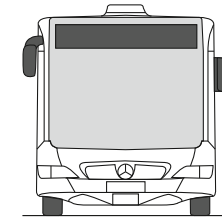
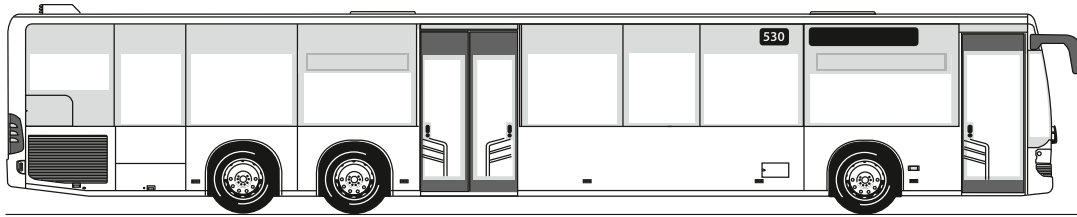

Citaro GÜ (C628.287)

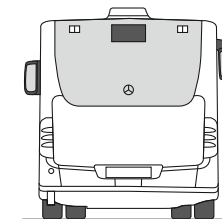
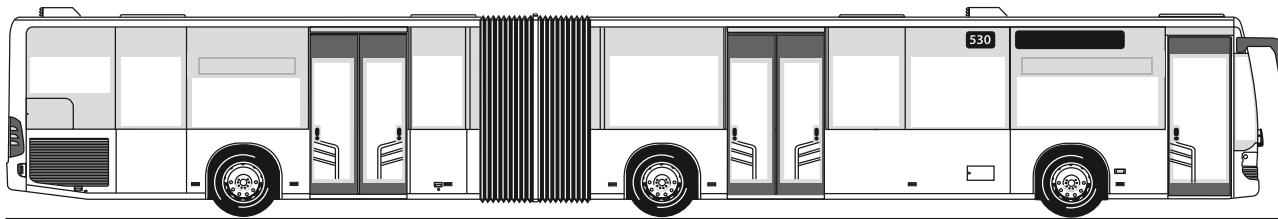

Dimensions/weights

	Citaro Ü	Citaro MÜ	Citaro LÜ	Citaro GÜ
Vehicle length	11,950 mm	13,008 mm	14,995 mm	17,940 mm
Vehicle width	2550 mm	2550 mm	2550 mm	2550 mm
Vehicle height (incl. air conditioning system)	3076 mm	3076 mm	3076 mm	3076 mm
Wheelbase, front axle - drive axle	5845 mm	6862 mm	7290 mm	-
Wheelbase, drive axle - trailing axle	-	-	1600 mm	-
Wheelbase, front axle - centre axle	-	-	-	5845 mm
Wheelbase, centre axle - drive axle	-	-	-	5990 mm
Overhang, front/rear	2705/3400 mm	2705/3441 mm	2705/3400 mm	2705/3400 mm
Angle of approach/departure	7°/7°	7°/7°	7°/7°	7°/7°
Tyre size	275/70 R 22.5	275/70 R 22.5	275/70 R 22.5	275/70 R 22.5
Overall passenger-carrying capacity	83	89	110	130
Seated	44	48	60	58
Standing	39	41	50	72
Boarding height, door 1/door 2/door 3	320/340/- mm	320/340/- mm	320/340/- mm	320/340/340 mm
Door opening width, door 1/door 2/door 3	780/1250/- mm	780/1250/- mm	780/1250/- mm	1250/1250/1250 mm
Headroom, front/rear	2313/2082 mm	2313/2082 mm	2313/2082 mm	2313/2082 mm
Floor height above road	370 mm	370 mm	370 mm	370 mm
Seat platform height, front/rear	190/280 mm	190/280 mm	190/250 mm	190/280 mm
Waist rail height (above floor)	950 mm	950 mm	950 mm	950 mm
Fuel tank capacity	350 l	350 l	350 l	350 l
AdBlue additive tank capacity	46 l	46 l	46 l	46 l
Gross vehicle weight, legally permissible*	18,000 kg	18,000 kg	24,000 kg	28,000 kg
Axle loads, permissible*				
- Front axle	6930 kg	6930 kg	6930 kg	6930 kg
- Centre axle	-	-	-	10,000 kg
- Drive axle	12,000 kg	12,000 kg	12,000 kg	12,000 kg
- Trailing axle	-	-	6930 kg	-

* Depends on country of registration, example shown: Germany

Turning circle

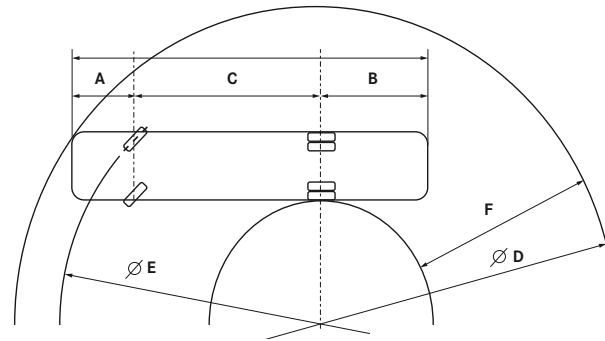

	Citaro Ü	Citaro MÜ
A: Front overhang	2705 mm	2705 mm
B: Rear overhang	3400 mm	3441 mm
C: Wheelbase	5845 mm	6862 mm
D: Minimum turning circle	21,030 mm	23,700 mm
E: Minimum track circle	16,908 mm	19,576 mm
F: Ring width for minimum turning circle	6758 mm	7222 mm
D: Turning circle as per BOKraft (Ordinance on the Operation of Passenger Transport Companies)	25,000 mm	25,000 mm
F: Ring width as per BOKraft (Ordinance on the Operation of Passenger Transport Companies)	5776 mm	6830 mm
F: Maximum permissible ring width as per BOKraft (Ordinance on the Operation of Passenger Transport Companies)	7200 mm	7200 mm
Maximum front-axle wheel angle, inner/outer wheel	53°/46°	53°/46°

Turning circle

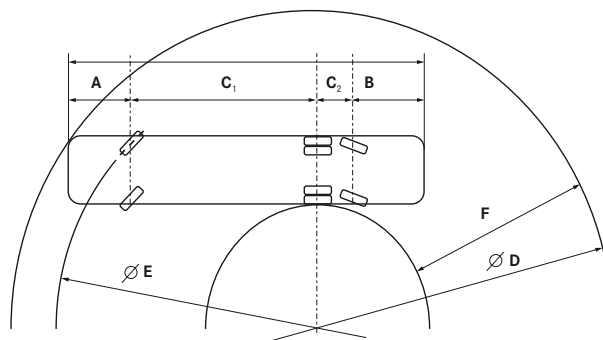

	Citaro LÜ
A: Front overhang	2705 mm
B: Rear overhang	3400 mm
C ₁ : Wheelbase, front axle - drive axle	7290 mm
C ₂ : Wheelbase, drive axle - trailing axle	1600 mm
D: Minimum turning circle	24,324 mm
E: Minimum track circle	20,200 mm
F: Ring width for minimum turning circle	7329 mm
D: Turning circle as per BOKraft (Ordinance on the Operation of Passenger Transport Companies)	25,000 mm
F: Ring width as per BOKraft (Ordinance on the Operation of Passenger Transport Companies)	7051 mm
F: Maximum permissible ring width as per BOKraft (Ordinance on the Operation of Passenger Transport Companies)	7200 mm
Maximum front-axle wheel angle, inner/outer wheel	53°/46°

Turning circle

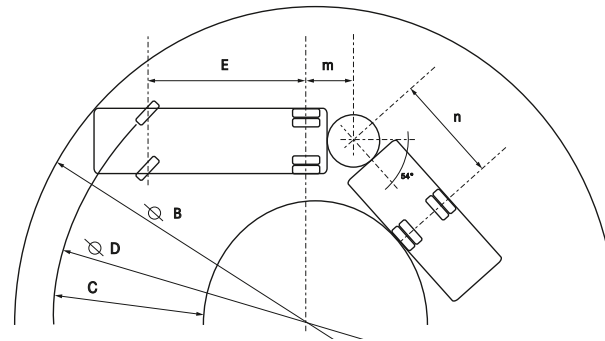

	Citaro GÜ
Front overhang	2705 mm
Rear overhang	3400 mm
E: Wheelbase, front axle - centre axle	5845 mm
m+n: Wheelbase, centre axle - drive axle	5990 mm
B: Minimum turning circle	22,850 mm
C: Ring width, minimum turning circle	7419 mm
D: Minimum track circle	19,086 mm
B: Turning circle as per BOKraft (Ordinance on the Operation of Passenger Transport Companies)	25,000 mm
C: Ring width as per BOKraft (Ordinance on the Operation of Passenger Transport Companies)	6706 mm
C: Maximum permissible ring width as per BOKraft (Ordinance on the Operation of Passenger Transport Companies)	7200 mm
Maximum front-axle wheel angle, inner/outer wheel	53°/46°

Powertrain/technology

Euro V engine

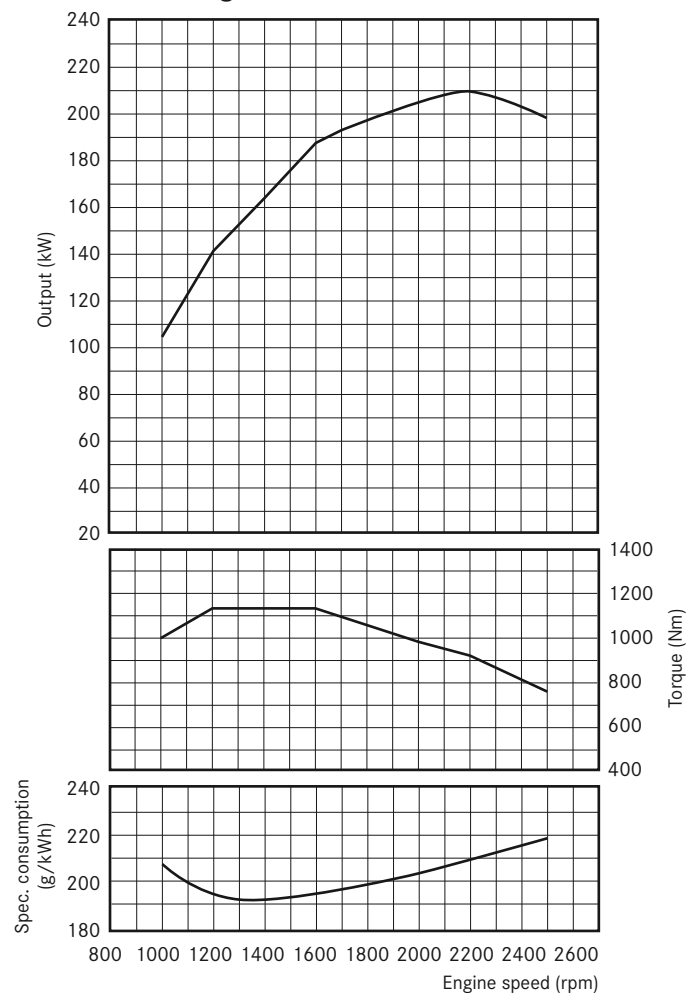

Max. output: 210 kW at 2200 rpm (80/1269/EEC)
 Max. torque: 1120 Nm at 1200 rpm, Torque rise = 19%

Steady-state full-load curves

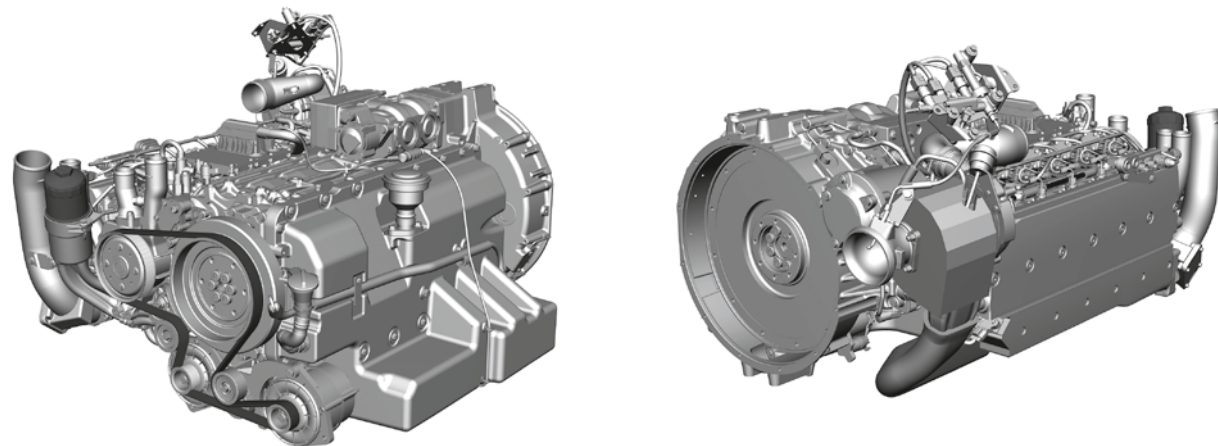

	Citaro Ü/MÜ
Engine (Euro V/EEV*)	OM 906 hLA
Displacement	6370 cc
Output (standard)	210 kW
Cylinders/arrangement	6/in-line
Max. torque	1120 Nm at 1200 rpm
Transmission	VOITH, 4-speed automatic transmission
Axles	
Front axle	ZF, independent suspension
Drive axle	ZF AV 132
Steering	ZF power steering
Brakes	Electronic braking system with disc brakes Anti-lock braking system (ABS)

* Our buses achieve the EEV emission standard (optional), depending on model and power unit, with or without a diesel particulate filter.

Powertrain/technology

Euro V engine

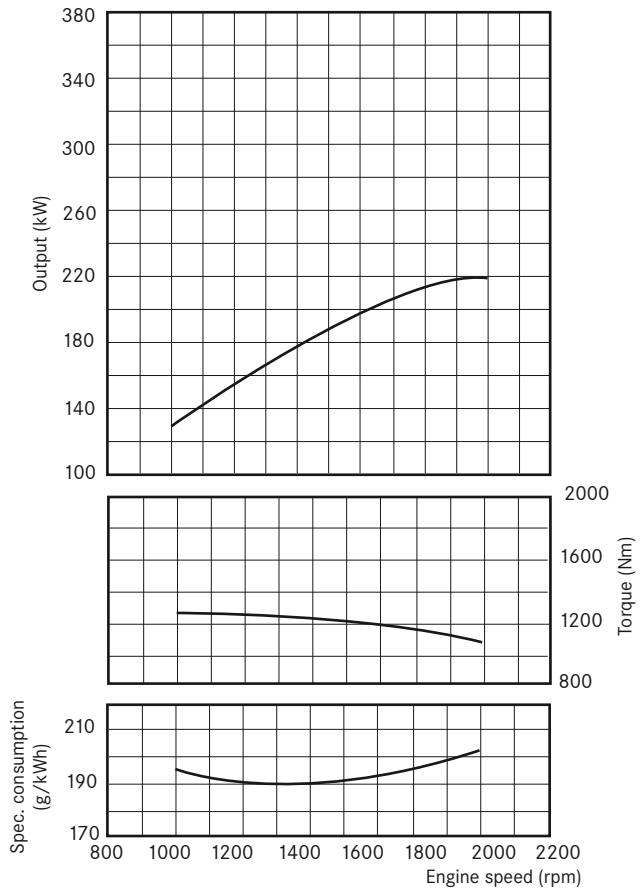

Max. output: 220 kW at 2000 rpm (80/1269/EEC)
 Max. torque: 1250 Nm at 1100 rpm, Torque rise = 19%

Steady-state full-load curves

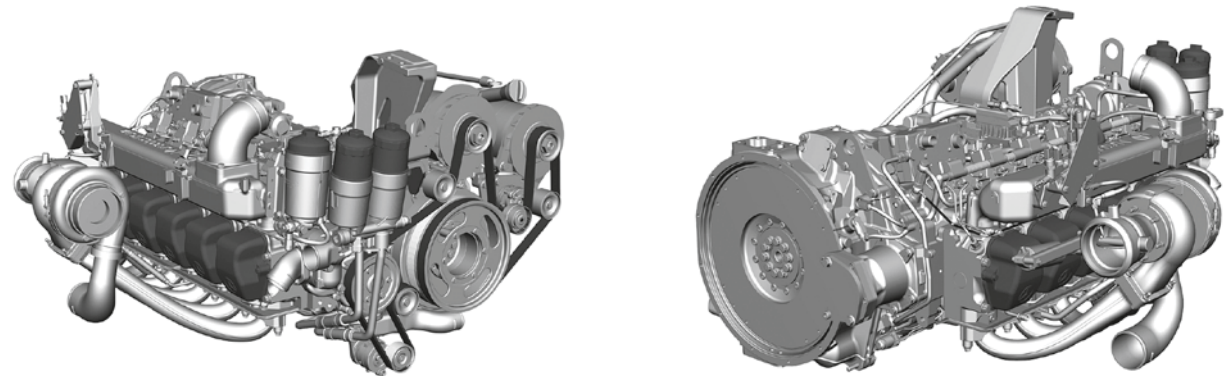

	Citaro LÜ/GÜ
Engine (Euro V/EEV)	OM 457 hLA
Displacement	11,967 cc
Output (standard)	220 kW
Cylinders/arrangement	6/in-line
Max. torque	1250 Nm at 1100 rpm
Transmission	VOITH, 4-speed automatic transmission
Axles	
Front axle	ZF, independent suspension
Centre axle (GÜ)	ZF AVN 132
Drive axle	ZF AV 132
Trailing axle (LÜ)	ZF RL 75/A
Steering	ZF power steering
Brakes	Electronic braking system with disc brakes Anti-lock braking system (ABS)

Citaro Ü (C628.087) seating configurations

Standard

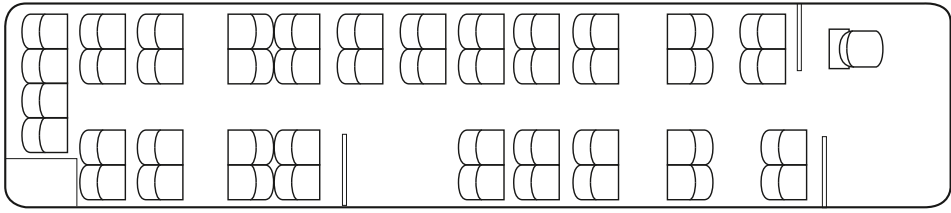

Number of seats 44

Special equipment (example)

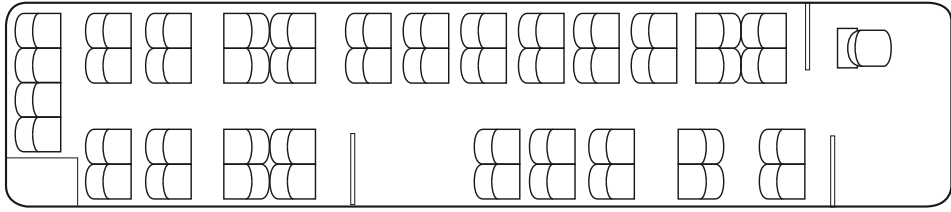

Number of seats 46

Special equipment (example)

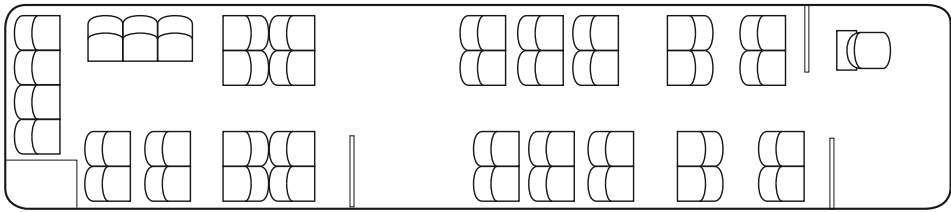

Number of seats 39

Citaro MÜ (C628.487) seating configurations

Standard

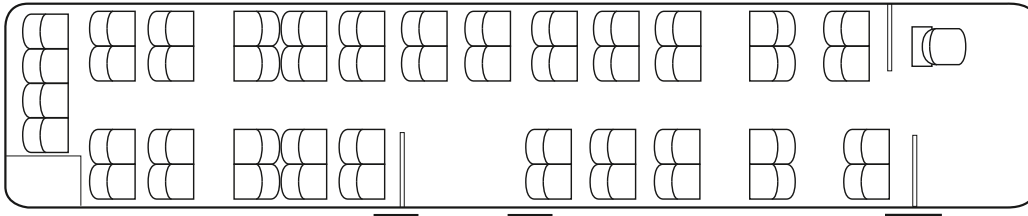

Number of seats

48

Special equipment (example)

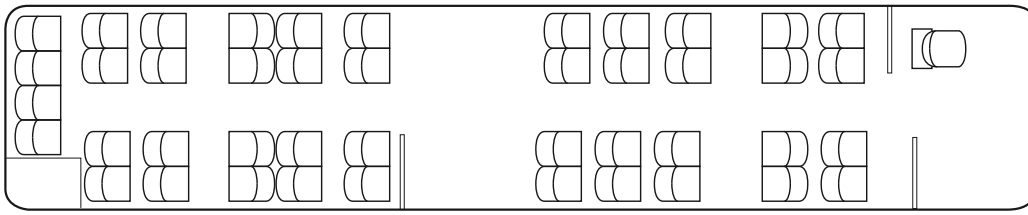

Number of seats

44

Special equipment (example)

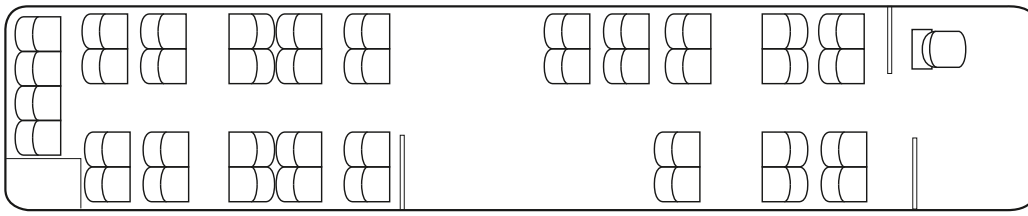

Number of seats

40

Citaro LÜ (C628.187) seating configurations

Standard

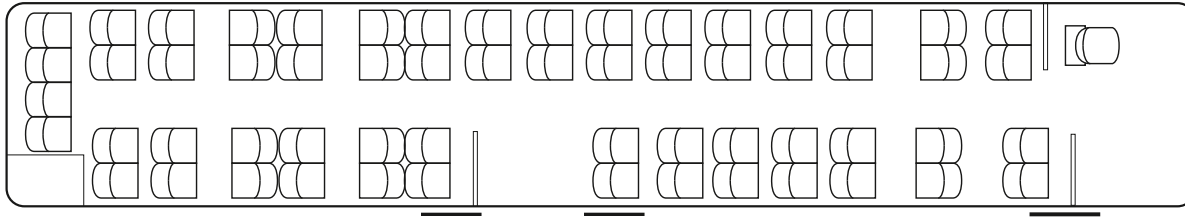

Number of seats

60

Special equipment (example)

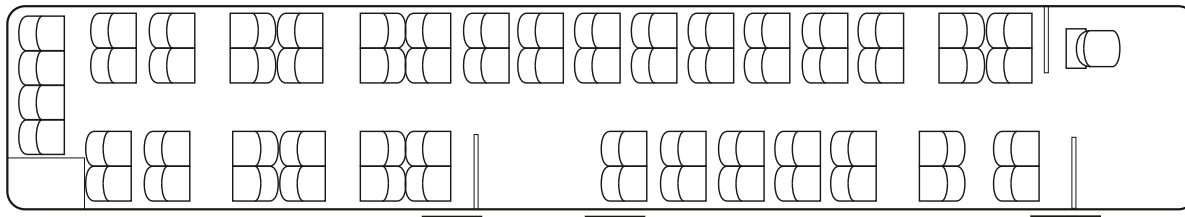

Number of seats

62

Special equipment (example)

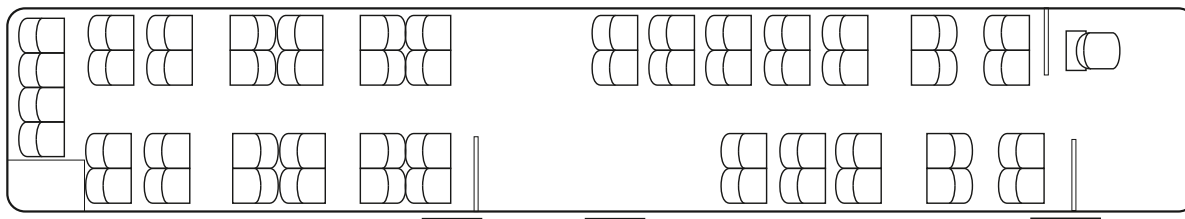

Number of seats

52

Citaro GÜ (C628.287) seating configurations

Standard

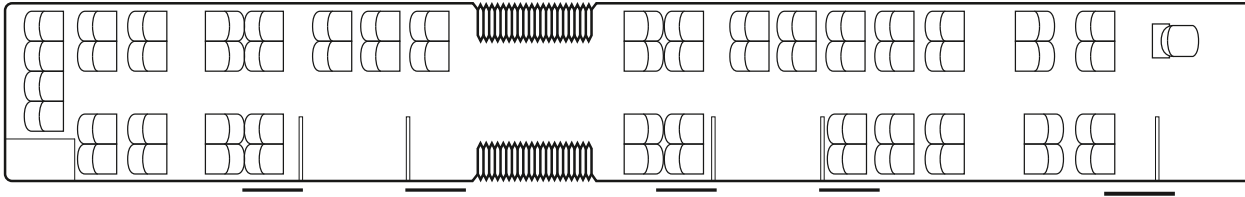

Number of seats

58

Special equipment (example)

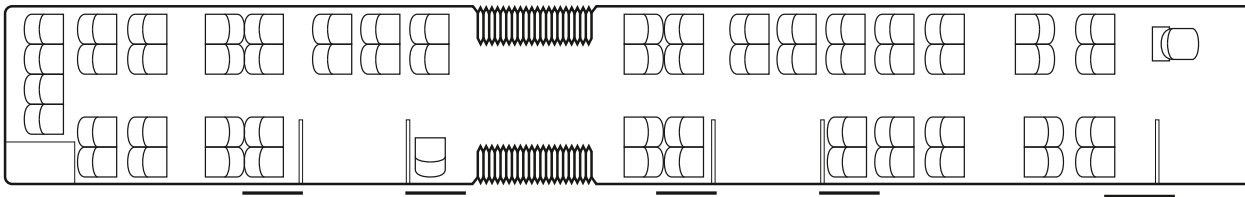

Number of seats

61

Special equipment (example)

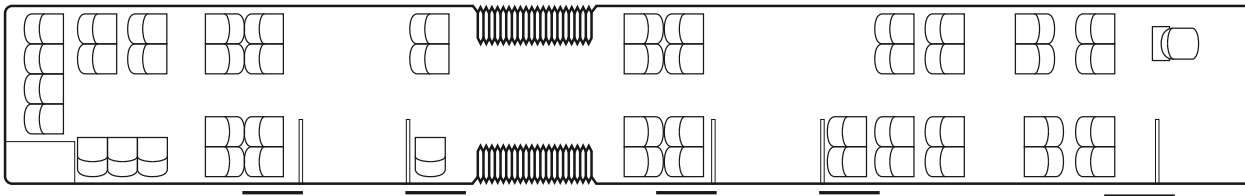

Number of seats

48

Standard/special equipment (selection)

Engine and chassis	Citaro Ü	Citaro MÜ	Citaro LÜ	Citaro GÜ
Engine: Mercedes-Benz OM 906 hLA 210 kW (Euro V)	●	●	-	-
Engine: Mercedes-Benz OM 457 hLA 220 kW (Euro V)	○	○	●	●
Engine: Mercedes-Benz OM 457 hLA 260 kW (Euro V)	○	○	○	○
EEV emissions standard	○	○	○	○
VOITH 5.0, 4-speed automatic transmission	●	●	●	●
ZF Ecomat, 6-speed automatic transmission	○	○	○	○
ZF Ecolife, 6-speed automatic transmission	-	-	○	-
Electronic braking system (EBS)	●	●	●	●
Anti-lock braking system (ABS)	●	●	●	●
Acceleration skid control (ASR)	○	○	○	○
Frequent-stop brake with drive-off lock	●	●	●	●
Air suspension by means of electronic level control (ENR)	●	●	●	●
Air suspension by means of electronic level control (ENR), including kneeling function	○	○	○	○
Vehicle height increase of 70 mm using button on instrument panel/console	○	○	○	○
Painted wheels/painted wheel trims	○	○	○	○
Plastic wheel trims	○	○	○	○
Stainless-steel wheel trims	○	○	○	○

● Standard equipment/no-cost option

○ Special equipment

Air conditioning system	Citaro Ü	Citaro MÜ	Citaro LÜ	Citaro GÜ
Turbo roof ventilator	●	●	●	●
Roof-duct ventilation system with integrated heating	○	○	○	○
Roof-mounted air conditioning system	-	-	-	○
Roof-mounted air conditioning system, uprated version	○	○	○	○
Roof-mounted air conditioning system, hot-climate version	○	-	-	-
Electrically opening roof hatch with automatic closing function (windscreen wipers activated, engine off)	●	●	●	●
Heating system with sidewall radiators	●	●	●	●
Heating system with convectors	○	○	○	○
Driver's area				
Driver's seat GRAMMER MSG 90.6 P, air-sprung	●	●	●	●
ISRI 6860/875 driver's seat, integrated pneumatic system, three-point seat belt	○	○	○	○
Heated driver's seat	●	●	●	●
Driver's area air conditioning	○	○	○	○
Driver's cab door	●	●	●	●
Compartment for driver's bag on driver's cab door, open	●	●	●	●
Compartment for driver's bag on driver's cab door, lockable, hinged	○	○	○	○
Pre-installation for ticket canceller, ticket counter, ticket printer	●	●	●	●
Steering column adjustable for height and angle, with steering wheel lock	●	●	●	●
Cruise control	○	○	○	○
Heated exterior mirrors approved for school buses	●	●	●	●
Heated exterior mirrors, electrically adjustable, approved for school buses	○	○	○	○
Driver microphone	●	●	●	●
Audible reversing warning	○	○	○	○
Roller sunblind covering 2/3 of windscreen, electrically operated	○	○	○	○
Interior video monitoring	○	○	○	○
Fire detection system for monitoring engine compartment (Standard as of 2011)	●	●	●	●
Extinguisher system	○	○	○	○

● Standard equipment/no-cost option

○ Special equipment

Interior	Citaro Ü	Citaro MÜ	Citaro LÜ	Citaro GÜ
Inter Star Eco (ISE) seats	●	●	●	●
Wheelchair space	○	○	○	○
Wheelchair parking wall with integral folding seat	○	○	○	○
Stop request button	●	●	●	●
Stowage facility on front left wheel arch	○	○	○	○
Emergency hammers secured by rope, automatic retractor	●	●	●	●
Emergency hammers with electric anti-theft alarm	○	○	○	○
Sidewall lining, needlefelt	○	○	○	○
Coat hooks on window pillars	○	○	○	○

Miscellaneous

Halogen fog lamps integrated in the bumper	●	●	●	●
Heat-insulating side windows, grey-tinted	○	○	○	○
Double-glazed side windows	○	○	○	○
Hinged windows in side windows	●	●	●	●
Sliding windows in side windows	○	○	○	○
Folding ramp at door 1 or 2, manually operated	○	○	○	○
Cassette ramp at door 2, manually or electrically operated	○	○	○	○
Ski-box bracket	○	-	-	-

● Standard equipment/no-cost option

○ Special equipment

Information and entertainment	Citaro Ü	Citaro MÜ	Citaro LÜ	Citaro GÜ
Radio system with CD player	<input type="radio"/>	<input type="radio"/>	<input type="radio"/>	<input type="radio"/>
Multifunction aerial for radio, mobile phone, navigation	<input type="radio"/>	<input type="radio"/>	<input type="radio"/>	<input type="radio"/>
Interior bus-stop indicator, on transverse duct	<input type="radio"/>	<input type="radio"/>	<input type="radio"/>	<input type="radio"/>
LED or LCD destination display	<input type="radio"/>	<input type="radio"/>	<input type="radio"/>	<input type="radio"/>
Wheelchair pushbutton, interior/exterior	<input type="radio"/>	<input type="radio"/>	<input type="radio"/>	<input type="radio"/>
GPS digital clock on front flap	<input type="radio"/>	<input type="radio"/>	<input type="radio"/>	<input type="radio"/>

● Standard equipment/no-cost option

○ Special equipment

Technical changes may have been made to the product since this data sheet went to press. This data sheet presents only a selection of the possible equipment. Some items of equipment are not available in all countries. The manufacturer reserves the right to make technical changes to the product. For current and more specific information, please contact your Mercedes-Benz sales advisor.

Glossary

Anti-lock braking system (ABS)

The braking forces acting on each wheel are distributed by ABS in such a way that none of the wheels locks for a significant length of time, even during emergency braking. Steering control of the bus is thus largely maintained.

Acceleration skid control (ASR)

ASR prevents the wheels from spinning when moving off on a slippery surface. It only delivers as much power as the driven wheels can transmit to the road surface. Spinning of individual wheels, on ice at the edge of the road, for example, is prevented by precisely metered brake applications.

Electronic level control system (ENR)

Passengers and baggage are not always distributed evenly throughout the vehicle. This can cause variations in the ride height at different wheels. The electronic level control system automatically controls the ride height at each wheel so that the boarding height is always the same.

Electronic braking system (EBS)

Developed from the conventional compressed-air brake, the Electronic Braking System offers many benefits. During braking, the control unit first calls on the permanent brake (retarder). If greater deceleration is required, the control unit uses information from the data network to calculate the optimum brake pressure for each axle. The Electronic Braking System enables considerably shorter stopping distances as well as significantly reduced wear of brake discs and pads.

Cathodic dip priming

Cathodic dip priming (CDP) is an electrochemical process in which the bodyshell is coated by immersion. It is well-suited to priming complex structures and large volumes. The water-based primer provides the bus with outstanding corrosion protection because the layer of paint is applied to every point of the body, covering them all to the same thickness. Cathodic dip priming is demonstrably the best method of corrosion protection currently available in the vehicle manufacturing sector.

For further information, please contact your Mercedes-Benz bus/coach representative.
Or visit us online at www.mercedes-benz.de/omnibus

The illustrations may show special equipment and accessories which are not part of the standard specification.
The technical data in this document apply to Germany (Status: July 2010). The manufacturer reserves the right to make changes to the product.